

ELMARK[®]

The Brand of Electricity

LED FLOODLIGHT

HELIOS SMD WITH SENSOR



GENERAL INFORMATION »

- ∴ Rated voltage: 176-264V/ 50-60Hz
- ∴ Power: 20W; 30W; 50W
- ∴ LED driver: mounting in the body
- ∴ Colour temperature: 5000-5500K
- ∴ LED source: Epistar SMD2835
- ∴ Colour: Black
- ∴ Body: Aluminium casting
- ∴ Beam angle: 120°
- ∴ Colour rendering index: Ra > 70
- ∴ Average lifetime: 15 000h
- ∴ Ambient temperature: -20°C ÷ +55°C
- ∴ Protection against dust and moisture: IP65

Sensor:

- ∴ Detection Range: 110°
- ∴ Detection Distance: MAX 8m (adjustable)
- ∴ Ambient Light: 2-1000 lux (adjustable)
- ∴ Detection Motion Speed: 0.6-1.5m/s;

FEATURES »

- ∴ Efficient replacement of traditional halogen and metal-halide floodlights
- ∴ Wide distribution of even and stable light
- ∴ Economic - low power consumption
- ∴ Repeated switch on/off does not affect the fixture lifespan
- ∴ Instant light at maximum luminous flux
- ∴ Environmentally friendly - no mercury and lead
- ∴ No ultraviolet and infrared rays
- ∴ Resistant to shock and vibration stable body
- ∴ Voltage supply fluctuations do not affect the normal operation of the floodlights

APPLICATION »

- ∴ Sports halls
- ∴ Commercial areas
- ∴ Warehouses
- ∴ Production facilities
- ∴ Squares
- ∴ Parking lots

PRODUCT DETAILS »

Catalogue number	Watt (W)	Whole fixture lumens (lm)	Colour temp (K)	Colour body
98HELIOS20SEN	20	1600	5000-5500	black
98HELIOS30SEN	30	2400	5000-5500	black
98HELIOS50SEN	50	4000	5000-5500	black

DIMENSIONS »

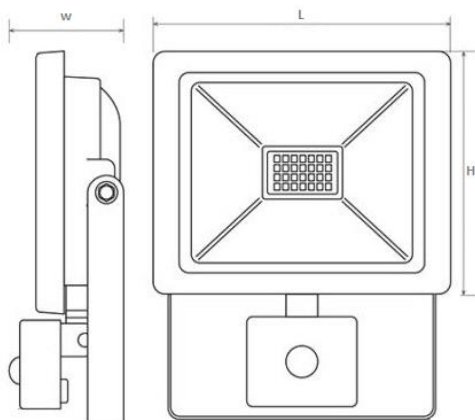

Model	Length (mm)	Width (mm)	Height (mm)
98HELIOS20SEN	134	35	109
98HELIOS30SEN	173	35	136
98HELIOS50SEN	210	35	163